

TYN1012, BTA08-600BW: SJ1,SJ2 open for 26Vdc input = spark

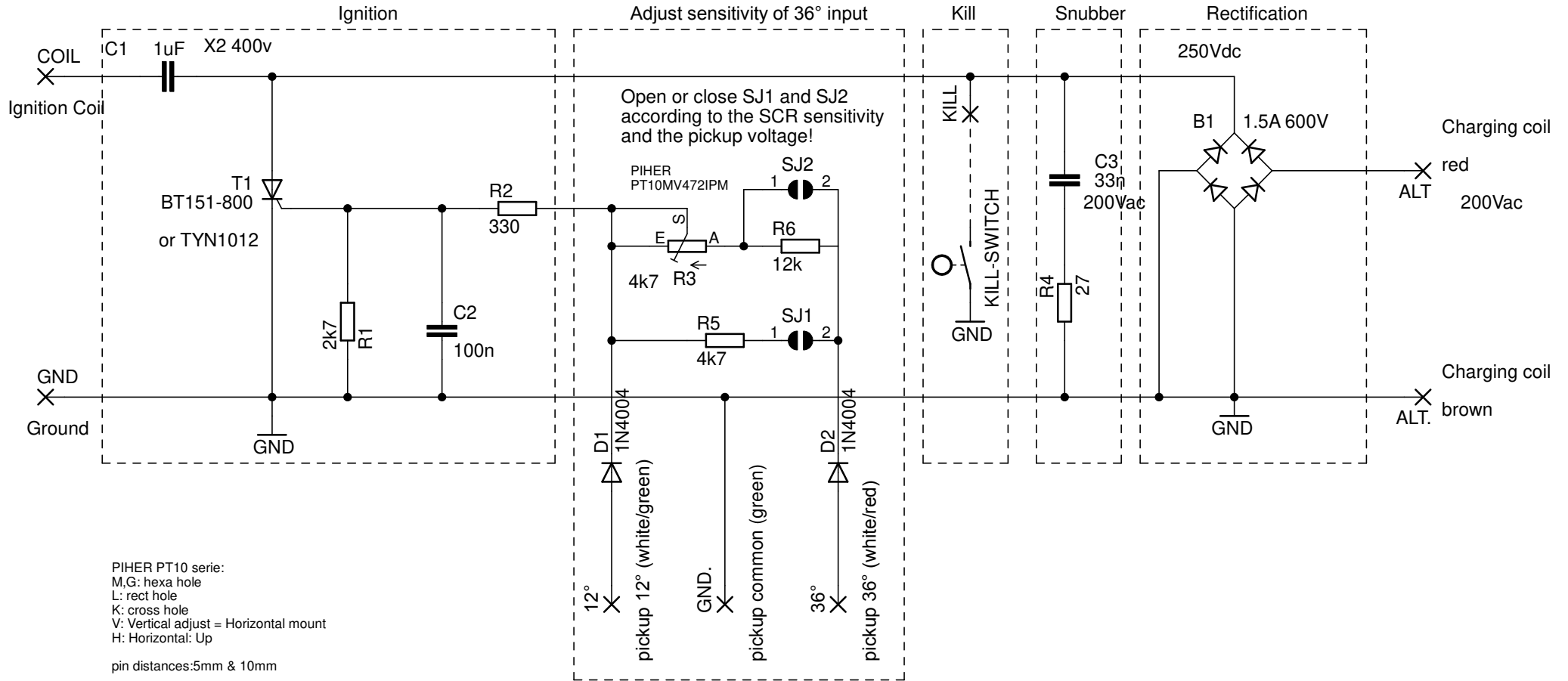

<https://transmic.net/2016/07/24/analog/>